

## protective tube luminaire

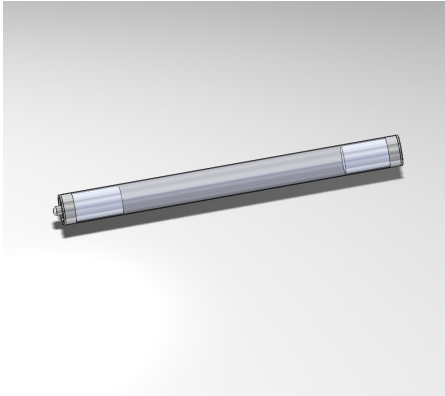

RL70- 110 S X

connected load  
fitted with  
  
work equipment  
mains lead  
luminaire body  
material  
weight (net)  
fastening  
light distribution  
system of protection  
class of protection  
total length  
light opening  
outside diameter  
end cap style article  
no.

remote ballast  
1 x LED LAMP 10W neutral white  
3300 -3500K 1100 lm  
optional electronic ballast  
connecting terminal  
  
acrylic (PMMA); satine  
approx. 2.5 kg (5.5 lbs)  
lamp bracket (accessory)  
360 degree  
IP 67  
I  
777 mm (30.6 in)  
533 mm (21 in)  
70 mm (2.75 in)  
A with screwed cable gland  
R7X2L0RRS

