

Waldmann Arm Solutions

A natural extension of your product – without the cost of new product development.

Manufacturing your own arm solutions can be time consuming and expensive. Maximize efficiency by teaming with Waldmann. Our engineering specialists will use their expertise to develop a logical, yet economical design that successfully integrates one of our top-quality, proven arm styles with your product. Through custom engineering and specialty mounting options, our arm becomes a seamless, natural extension of your product.

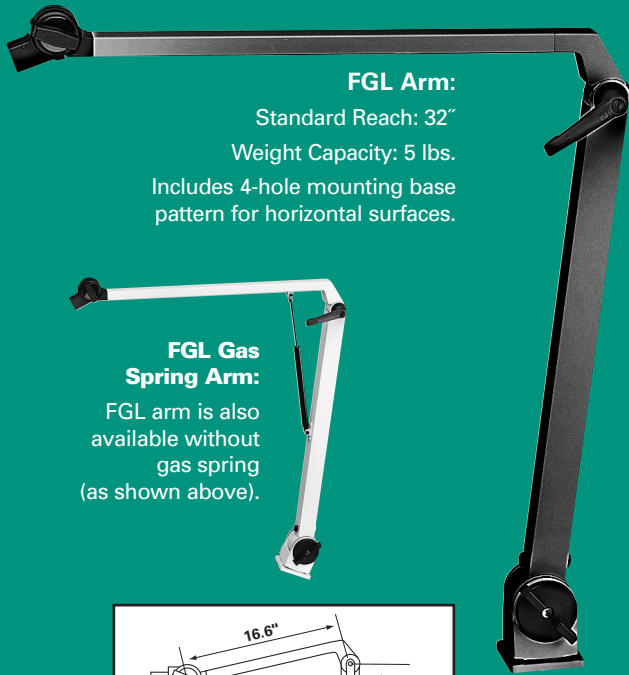

FGL Arm:
Standard Reach: 32"
Weight Capacity: 5 lbs.
Includes 4-hole mounting base pattern for horizontal surfaces.

FGL Gas Spring Arm:
FGL arm is also available without gas spring (as shown above).

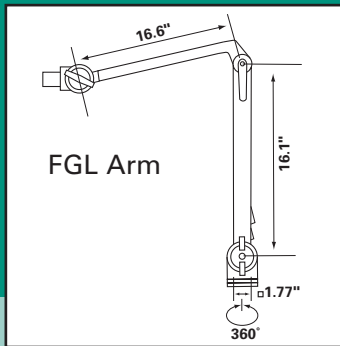

MLX Arm:
Standard Reach: 32"
Weight Capacity: 2 lbs.
Top joint best for pin type fixation of device.
Articulation points can be rendered flexible or locked into place.
A universal base is available for horizontal and vertical mounting.
Bolt/tamper proof configuration is available.
Custom arm lengths are available.

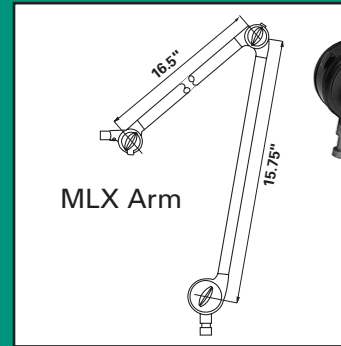

The strongest arms for the strongest solutions.

Our Waldmann arm systems are constructed using time-tested engineering, attributing to their robust durability. They feature flexible pivoting and articulating joints that offer stay-put reliability, and are designed with internal spring and band mechanisms.

Our arms are open to any application!

Whether you are looking to replace a current arm, or you need a new arm solution please call us today at **800.634.0007**.

The standard internal spring supports 2-3 lbs. Heavier springs are available upon request.

