

RL70 SERIES MOUNTING

Cable Suspension Mounting Instructions For RL70 Luminaire

Intended use

The RL70 tube luminaires are suspended horizontally via cables from a ceiling mounted canopy. The Pendant Strap Bracket or the Pendant Aluminum Bracket are available.

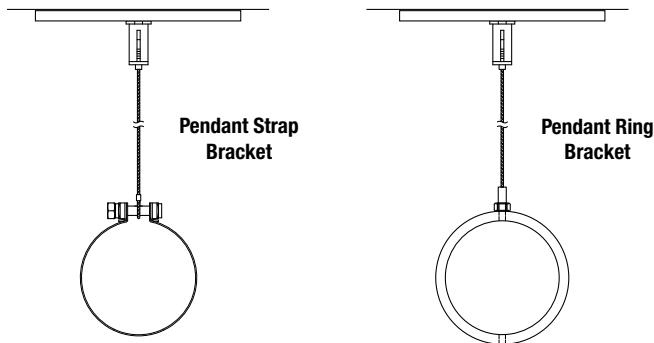

i Important note!

Please make sure to observe the safety instructions and warnings given in the operating instructions of the luminaire.

! Safety Instructions

Mount the luminaire indoor or outdoor in wet or dry locations, **not subject to explosion hazards!**

Mount the luminaire only to a suitable ceiling surface using appropriate screws or fasteners.

Mounting and connection of the luminaire must be carried out by a **qualified electrician** and must be wired in accordance with the National Electrical Code and applicable local codes. Proper grounding is required for safety.

Warning: Make certain power is OFF before installing or maintaining the luminaire.

A Recommended Mounting

Optional canopy kits can be ordered so that the RL70 luminaire can be suspended using the cable and cable connector furnished with each fixture bracket.

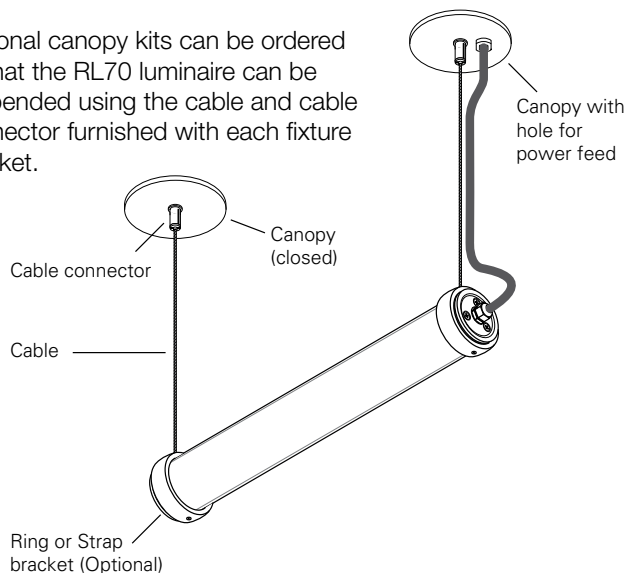

B Bracket Spacing

The Pendant Strap Bracket or Pendant Ring Bracket should be placed a maximum of 6 inches from each end of the luminaire. This will help you determine how far apart to place the ceiling canopies.

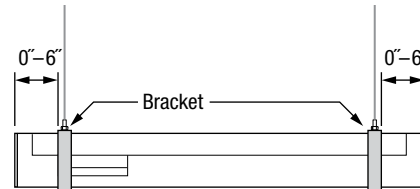

C Alternate Bracket Spacing for Luminaires

For luminaires with the ballast compartment at end of luminaire, place one bracket near the end of the ballast compartment as shown below.

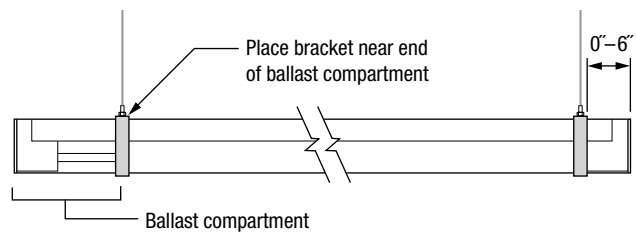

D Mounting and Wiring the Luminaire

Please Note: Before mounting and wiring the luminaire, the installer will need to determine the length of power cable required. The luminaire power cable must be connected to the building feed first, along with the canopy assembly. The luminaire may have been factory pre-wired with a specified length of power cable. Removal of the luminaire end cap is required for proper installation. Note: If you are field wiring the luminaire, you will still need to remove the end cap. Step 'F' explains how to attach the power cable to the end cap socket.

1. Loosen all three phillips head screws that attach the End Cap just to the point where the heads are out past the End Cap. Remove the End Cap with inner piece and O-ring attached. If the luminaire has been factory wired, unplug the connector and set luminaire aside.

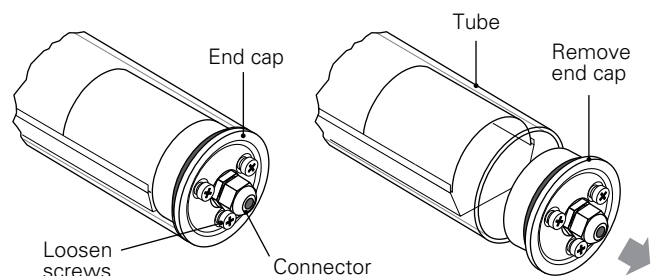

continued on next page

RL70 SERIES MOUNTING

Cable Suspension Mounting Instructions For RL70 Luminaire

continued on next page 1

- Attach mounting strap to junction box and insert the short threaded stud into the mounting strap. Insert the power cable with strain relief bushing attached into the large hole in the (optional) canopy. Attach hot, neutral, and ground wires to appropriate building wiring. Secure canopy by attaching the threaded cable holder with cable to the threaded stud.

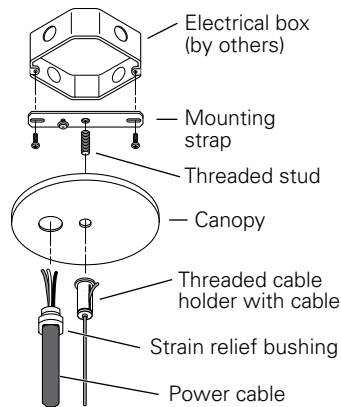

E Install Ring or Strap Brackets

- Slide Ring or Strap Bracket onto each end of tube. Do not fully tighten at this time.

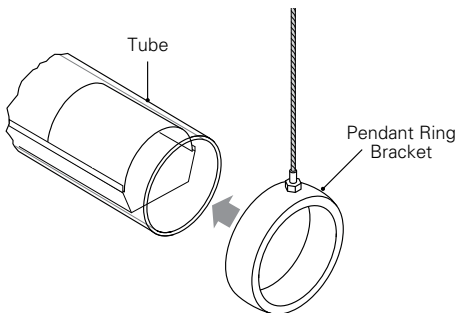

- Attach plug from luminaire to socket on end cap.

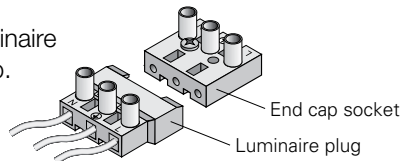

Installer Please Note - If the luminaires were pre-wired at the factory, proceed to Step G. If you are wiring the luminaire in the field, go to Step F and then to Step G.

F Wiring the RL70 Luminaire

- Insert electric cable through connector in end cap. Cable diameter to be .340" diameter, 3-conductor. Attach hot, neutral, and ground wires to socket. Observe labeling at the socket strip. Be sure to tighten the connector nut.

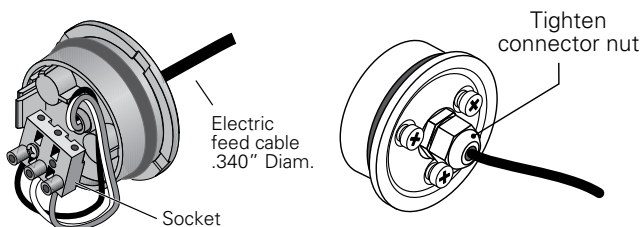

G Reassemble the Luminaire

- Replace the inner cover and slide wireway back into tube with end cap attached.

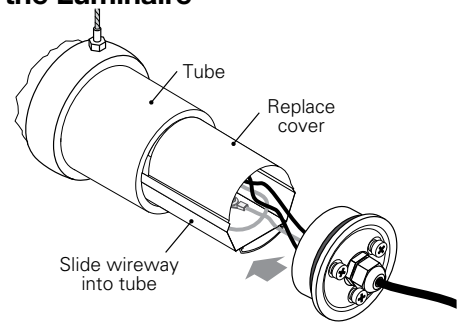

- Insert the end cap into the end of the tube. Tighten all three, (3) phillips head screws to seal end cap. Make sure the end cap fits properly. Align wireway so there is no gap between the tube and end cap.

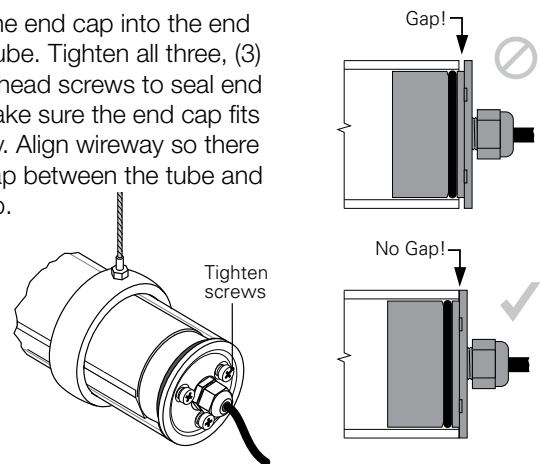

H Final Adjustments

- Adjust suspension cable length using a screwdriver to push up on pin where cable goes through. As you push up on the pin, the cable will release so be sure you hold onto the cable or it will slip out.
- Cut excess cable after you have achieved final position.

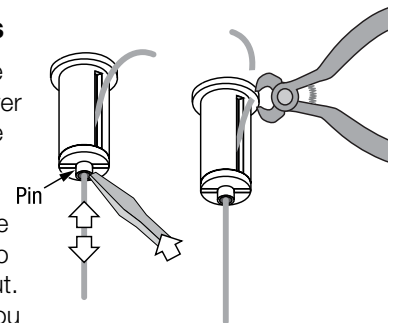

- Tighten screws on brackets. Strap bracket has socket head screw. Ring bracket has set screw at the bottom.

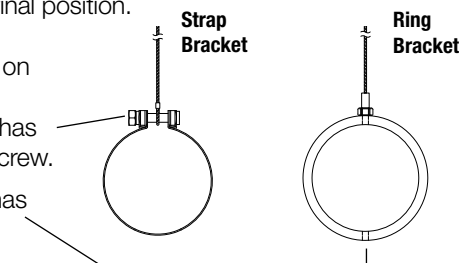

I Tandem/Continuous Mounting for the RL70

A separate data sheet is available which covers the requirements for continuous wiring of the RL70 luminaires. Consult factory for further information.

