

LED machine luminaire

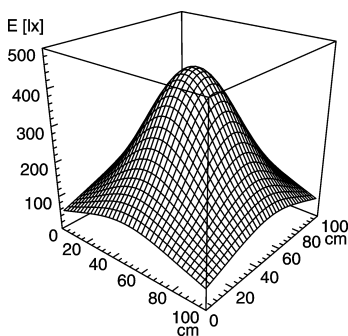

MACH LED PRO - MUAL 1 S

connected load	24 V; 50/60 Hz
fitted with	1 x LED lamp 5 W
work equipment	without
mains lead	approx. 3.0 m; with free stranded wires
design	mounted version
luminaire body	
material	aluminium
surface	anodised
weight (net)	approx. 0,4 kg
fastening	screws
technology	switchable
usage	without switch
lamp cover	screen; clear
glare-free	without
system of protection	IP 67
class of protection	III
total length	220 mm
special features	mounted version,
article no.	112571023



Emin: 64 lx
 Em: 203 lx
 Emax: 434 lx

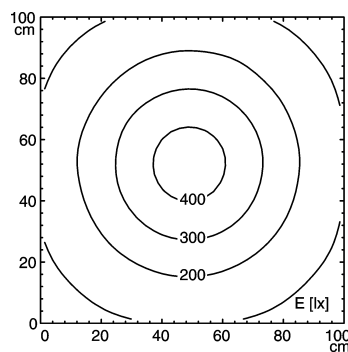

measuring conditions: d=50cm

