

LED machine luminaire

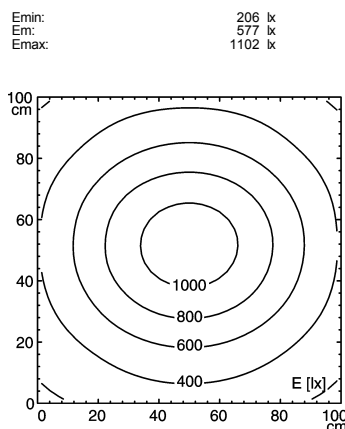

MACH LED PRO - MUEL 3 S

connected load	24 V; 50/60 Hz
fitted with	3 x LED lamp 5 W
work equipment	without
mains lead	approx. 3.0 m; with free stranded wires
design	integrated version
luminaire body	
material	aluminium
surface	anodised
weight (net)	approx. 0,9 kg
fastening	screws
technology	switchable
usage	without switch
lamp cover	screen; clear
glare-free	without
system of protection	IP 67
class of protection	III
total length	570 mm
special features	integrated version,
article no.	112571013

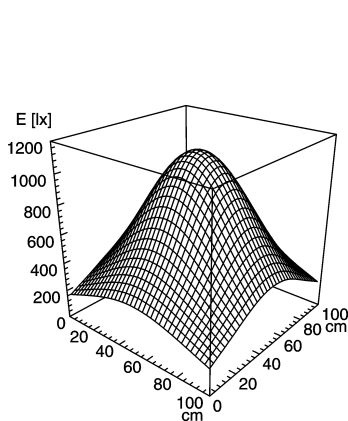

measuring conditions: d=50cm

