

## protective tube luminaire



**RL40E - 117**

connected load	120-240V; 50/60Hz
fitted with	1 x fluorescent lamp T8 17 W neutral white 4000 K
work equipment	electronic ballast
mains lead	direct power supply
luminaire body material	PMMA polymer acrylic clear
weight (net)	approx. 0,8 kg (1.8 lbs)
fastening	different mounting options available
light distribution	mainly direct
system of protection	IP 67
class of protection	I
total length	1054 mm (41.5")
light output	590 mm (23.2")
outside diameter	40 mm (1.6")
article no.	D with screwed cable gland 112259705

**Notice**

Switching cycle – In order to achieve a maximum life cycle of lamps and electronic ballasts using i.e. motion detectors PIR (Passive Infrared Sensor) or stairways' automats please consider that a minimum burning time of 15 minutes and a neutral phase of > 3 minutes will be fixed.

E<sub>min</sub>: 106 lx  
E<sub>m</sub>: 145 lx  
E<sub>max</sub>: 176 lx

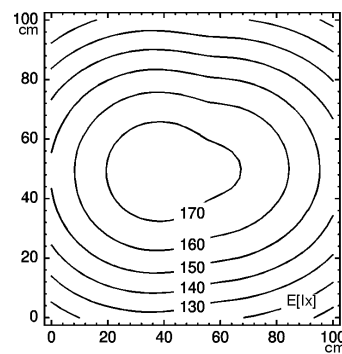
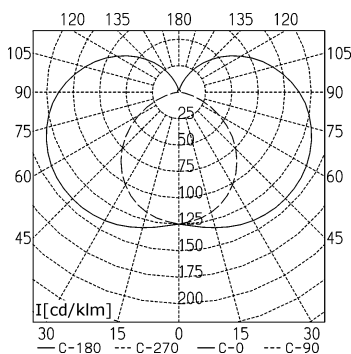

measuring conditions: d=100cm

